



JetBlade Hand Dryer

User Manual



PLEASE READ CAREFULLY THROUGH THIS MANUAL BEFORE USING THE PRODUCT, OBSERVING ALL SAFETY INFORMATION, WARNINGS.

SAFETY WARNINGS

Before installing, be sure to read this installation manual and retain for future reference.

This product must be installed by qualified personnel in accordance with the instructions given in this manual and installation must comply with all applicable regulations, national security standards and laws in force in the country where the product is installed.

Turn off the power at the main switch before installing or servicing the dryer unit

The dryer must not be installed on a flammable surface. Do not damage any parts of the electrical connections.

Pre-arrange an appropriate power outlet and a system of disconnection in accordance with current local regulations. Make sure the product is properly connected to ground. If there is no ground connection, there is a risk of an electrical shock.

Do not install the dryer over a washbasin. If the power cord is damaged, it must be repaired by qualified personnel to avoid any type of risk.

This dryer can be used by children aged 8 years and above. People with reduced physical, sensory or mental abilities or lack of experience and knowledge, if they have been given supervision and appropriate training regarding the use of the dryer in a safe manner, can use it with no restriction. Children should not play with the apparatus. Cleaning and maintenance performed by the owner should not be done without the children having supervision.

During use, temperatures above 158°F [70°C] may develop in the parts near the hot air nozzle. Do not touch or cover the dryer during use or when finished using it.

General safety information:

⚠ WARNING This product is intended for installation by a qualified service person. Use AWG NO. 12 solid conductor for wiring.

⚠ DANGER Failure to properly ground unit could result in service electrical shock and/or death.

⚠ WARNING Disconnect power at the service breaker before installing or servicing.

⚠ WARNING All units must be supplied with a 3-wire service. The ground wire must be connected to the dryer's backplate.

--**NOTE:** Do not install dryer over washbasin --

PACKING LIST

ITEM KEY	ITEM DESCRIPTION	ITEM QTY	NOTES
A	Hand Dryer Unit Complete	1	High Impact ABS plastic
B	Owner Manual(OM - this booklet)	1	
C	Mounting Template(MT)	1	
D	Wall Anchors, Expansion	8	Φ6x28MM [15/64" Dia.x 1-7/64"], for#5
E	Self-threading Phillips PH Screws	8	M4x20MM [No.8 AB x 25/32"]
F	Installation Bracket	1	Fixed on wall

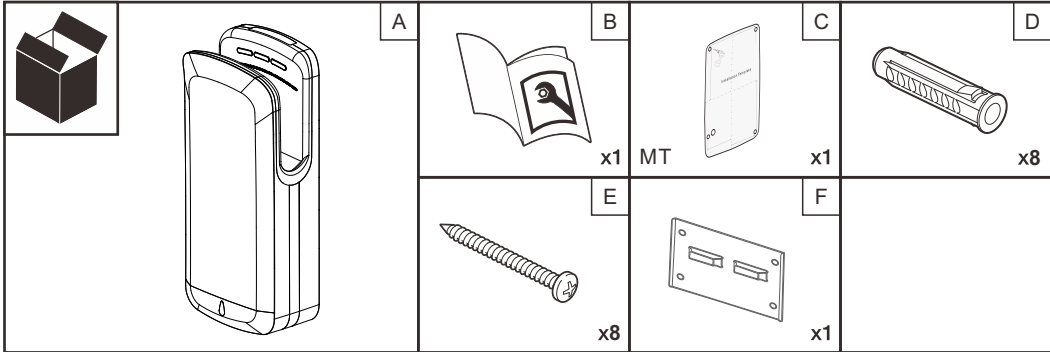

SPECIFICATION

Voltage:	220V-240 V 50/60 Hz, 7.17 A, 1650 W 110V-120 V 60 Hz, 13.75 A, 1650 W	}  ONLY be used on same voltage as product rated label marked.
Stand-by Power:	Less than 2.0 W	
Air Temperature:	40 °C [104 °F] (Room Temp.=25 °C [77 °F])	
Air Velocity:	150 M/ S [492 FT/S] / 540 KM/H [336MPH]	
Air Flow:	120 M ³ /H [70.5 CFM]	
Drying Time:	8-10 Seconds	
Timing Protection:	Forced Hold-On 25 Seconds auto shut-off	
Timing Duration:	Auto Shut-Off ≤3 Seconds after last sensor read	
Fuse Protection:	Main PCB, Φ5x20, 250 V, 12 A [230 V] / 20 A [120 V]	
Protection Level:	IP23	
Electric Isolation:	CLASS II	
Brush Motor:	30,000 RPM, 1250 W [1.70 HP]	
Noise [at 1M]:	74 dB	
Net Weight:	8.8 KG [19.4 lb]	
Gross Weight:	10.6 KG [23.4 lb]	

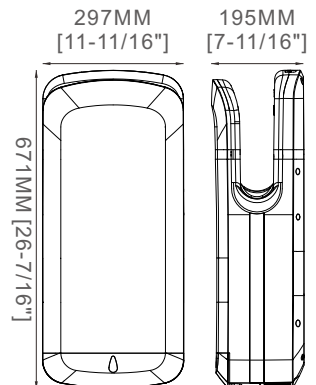

BEFORE INSTALLATION

Installation must be carried out in accordance with the current edition of the local wiring regulations code having jurisdiction. Installation should be performed only by a qualified electrician.



Please check if hand dryer is supplied with convenient plug in feature.

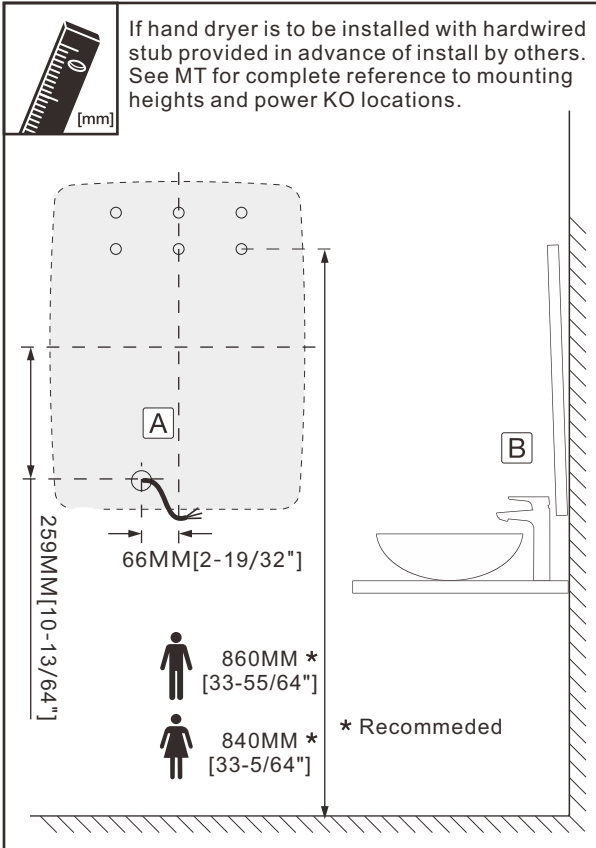

A L Min. = 500 MM [19-11/16"]

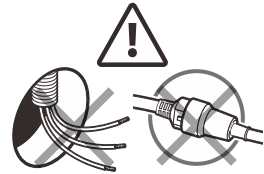
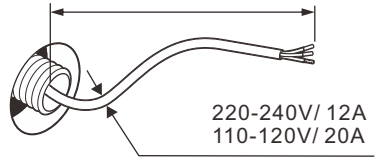

B

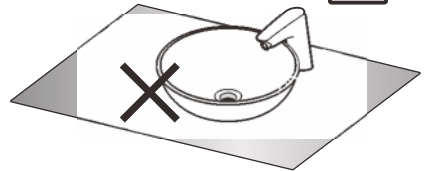

It is recommended to avoid installation of dryer near high reflective objects (mirror, stainless steel washbasins, etc.) in order to avoid faulty function of the presence sensor.

INSTALLATION

1. Make sure power supply breaker is switched off. Installation must adhere to the regulations of the current edition of the local wiring code having jurisdiction. Installation should be performed only by a qualified electrician.
2. Place Template against wall at desired height (see mounting height recommendations on MT) and mark locations of eight (8) mounting holes and wire service entry at hard wire entrance.
Note: For two(2) or more dryers units, units should be no closer than 610MM [24"] on centers.
3. Drill the marked hole at $\Phi 8\text{MM}$ / depth 38MM.
4. Insert Wall Anchors, Expansion [D] inside hole.
5. Fix Installation Bracket [G] on wall.
6. If the hand dryer is supplied in hard wire type:

- A. Open hand dryer back Terminal Block cover.
 - B. Connect live wire(Coloured Brown, Red, or Black) to the terminal block marked "L".
 - C. Connect neutral wire(Coloured Black, Blue) to the terminal block marked "N".
 - D. Replace Terminal Block cover.
 - E. Hang hand dryer on Wall Bracket [G]. Slid it lightly from up to down then it is locked.
7. If hand dryer is supplied with cable & plug then do up action " E " to hang hand dryer.
 8. Move the hand dryer bottom Switch Cover. Lock hand dryer by two theftproof screws.
 9. Before replace Switch Cover:
 - A. Check if the hand dryer power switch ON [Left switch].
 - B. There is an option to run the dryer heat element On or OFF[Right up switch].
 - C. There is an option to run air speed High or Low [Right low switch].
 There switch is clearly marked too.
 10. Replace the Switch Cover.

1 CIRCUIT BREAKER [By others]

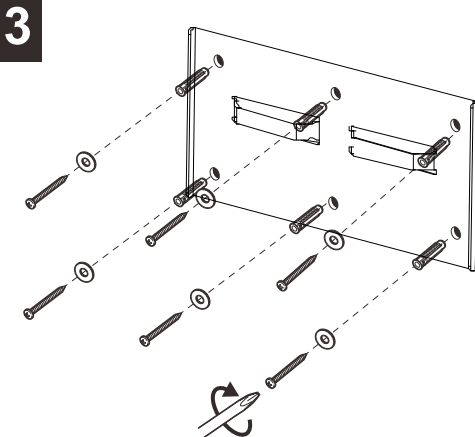
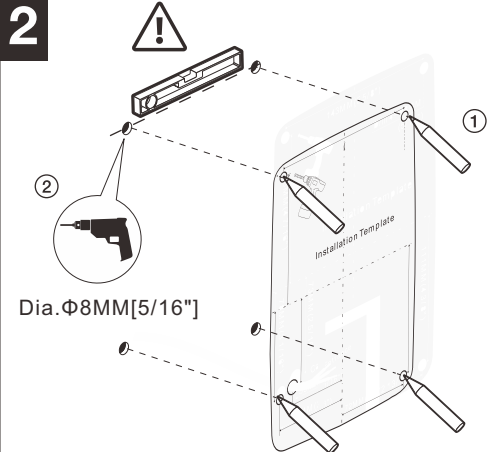
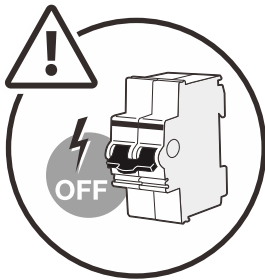

4 HARD WIRE ONLY

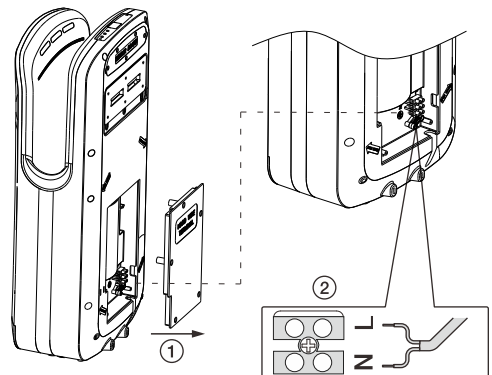

5

- A Coarse Particulate Filter
- B Air Inlet Grill

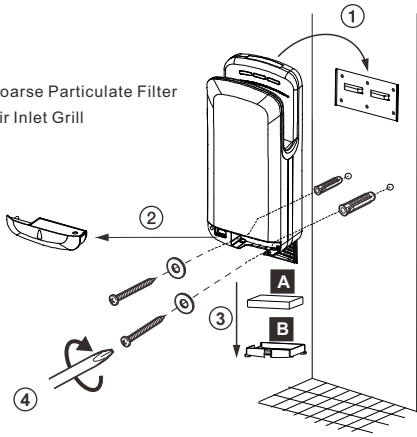

6

POWER ON/OFF OPTION

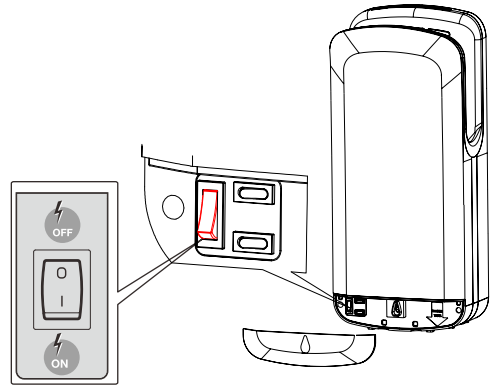

7

HOT AIR ON/OFF OPTION

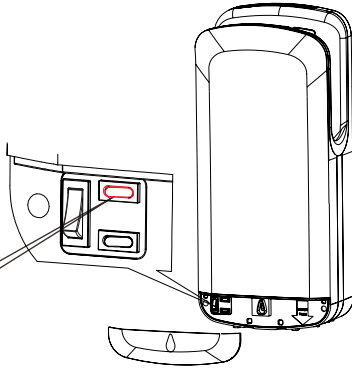
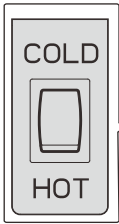

8

AIRFLOW SPEED HIGH/LOW OPTION

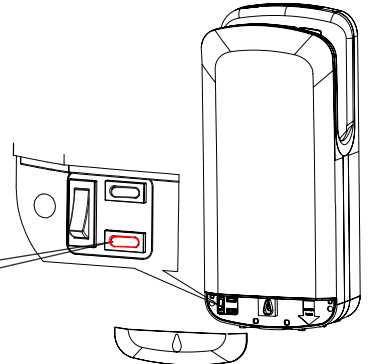
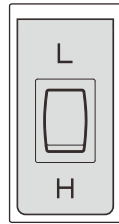

9

REPLACE SWITCH COVER

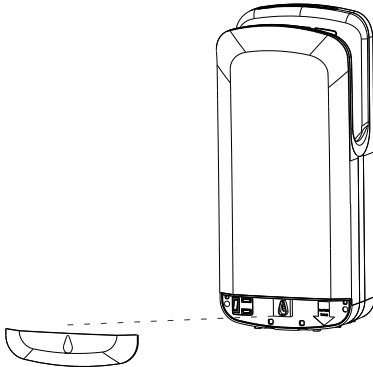

10

PLUG IN/TURN ON CIRCUIT BREAKER





BASIC USE

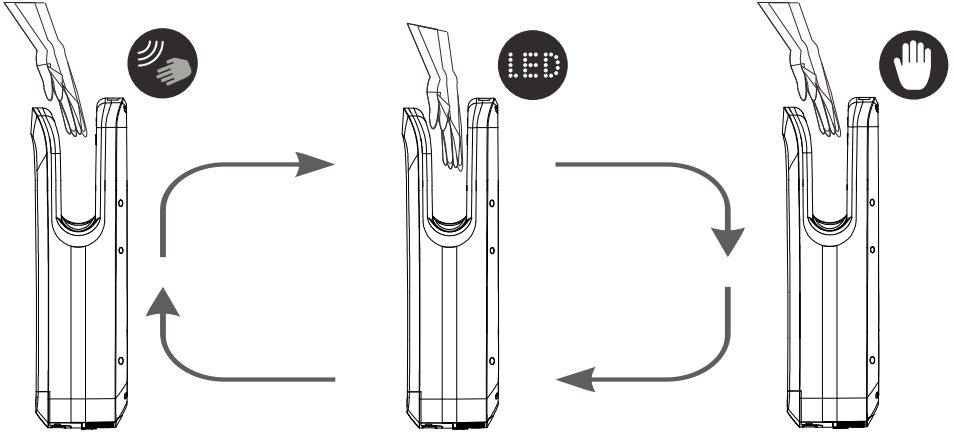

Operation without touching, place your hands at drying cavity to activate the device.

Externally visible service blue LED light guides hands to air flow.

After 3 seconds without detecting hands, the device stops automatically.

DIAGNOSTICS & REMEDIES

SYMPTOM	CORRECTIVE ACTION
Hand dryer fails to start	Ensure the breaker supplying the dryer is operational. If it is, disconnect the power and remove the hand dryer cover. Check all the wire connection to sure they are well fixed. Turn on power and verify correct power at terminal block. If it does not work then replace circuit board.
Hand dryer turns on/off erratically or not sensitive enough	Ensure that there is no obstruction on or in front of the infrared sensor zone. Clean any dirt off the sensor lens. Try adjusting the sensitivity potentiometer on program board. If it still does not still not work, replace circuit board and sensor board.
Not hot air	Check if the heat element switch is set for power on. Check if the heat element is broken. If yes, replace with a new one.
Hand dryer makes ticking noise	Check the motor brush wear down condition. Replace them if worn out or install a new motor. Disconnect power, remove cover, check to make sure no object is stuck in motor vents.

HEPA CLEAN & REPLACEMENT

The service life of a HEPA filter depends on the environment in which the dryer is installed and frequency of use. High traffic washrooms or high usage will require more frequent inspection and replacement of the HEPA filter. The HEPA filter should be inspected at least four times per year in washrooms with light to moderate traffic and normal environments.

In environments with excessive, dust and debris or in washrooms with high traffic, inspection of the HEPA filter is recommended on a monthly basis. When visual inspection of the HEPA filter shows excessive buildup of lint, dust and debris, the filter should be replaced.

Examining and changing a HEPA filter regularly keeps hand dryers working efficiently. Operating a hand dryer with an excessively dirty or clogged filter can damage your machine. The HEPA filter cannot be cleaned and re-used. Do not clean the HEPA filter or allow it to come into contact with water.

The hand dryer is also workable with Coarse Particulate Filter. The dryer has a coarse particulate air filter to prevent lint and debris build up that can damage the motor and heating element. Routine replacement or cleaning of the air filter is needed to maintain the dryer in good operating condition. With light to moderate wash room traffic, replacing or cleaning the air filter once a year is recommended.

If the wash room traffic is high, the air filter should be replaced or cleaned every 6 months.

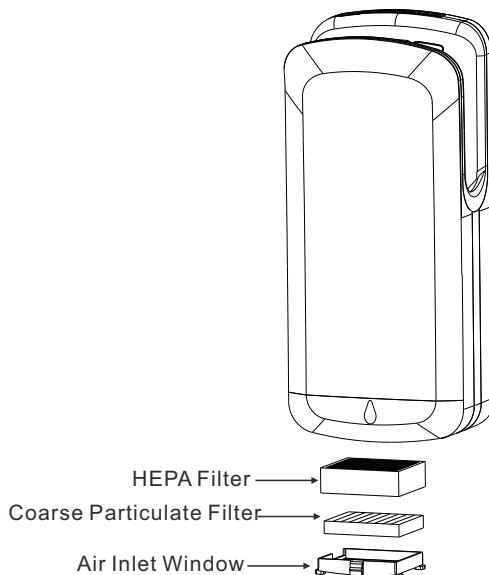

EMPTY WATER TRAY

Regular empty water tray is required. The smart water level indicator is flashing when water is full. It is available to push the water tray bottom piston to release water or move whole water tray unit to empty it.

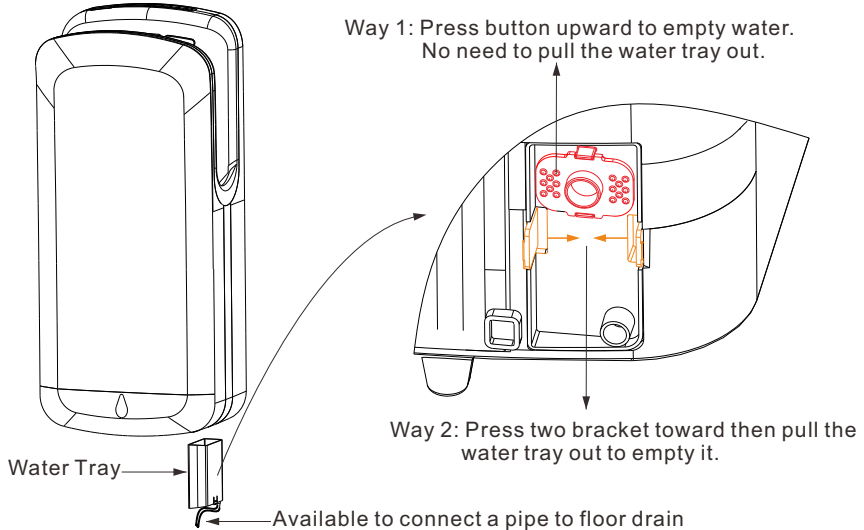

Replace Sensor Detector & LED Light Circuit Board

1. Move screw on sensor detector&LED light circuit board holder. Use a screwdriver to pull the cover a little to open it.
2. Take cover out lightly and the circuit board will come together ! Be careful there is wire connected on the circuit board.
3. Loosen two screws on circuit board and replace a new one.

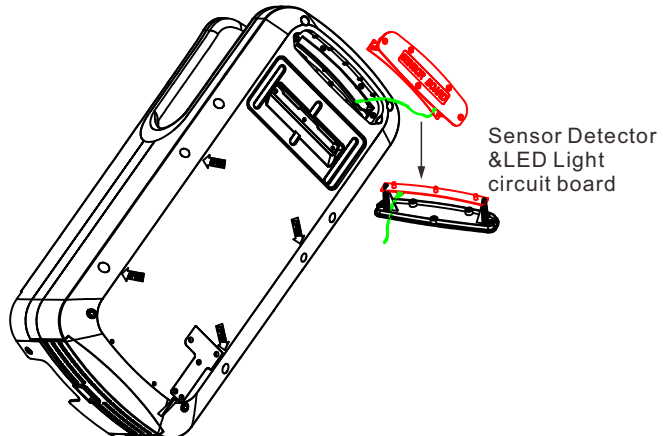

Replace Display Circuit Board

1. Move the sticker away. Do not damage the hand dryer edge as it will affect the surface appearance.
2. Move two screws on timer circuit board holder. Use a screwdriver to pull the holder a little to open it.
3. Take holder out and circuit board will come together. Be careful the connection wire.
4. Move two screws on circuit board and replace a new one.
5. Replacing new circuit board. It is suggested to use a new sticker for best appearance.

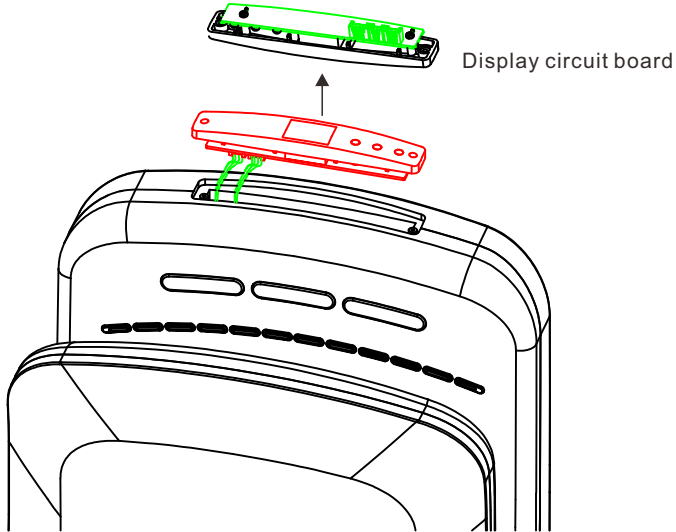

Open Hand Dryer Front Cover

1. Loosen 4 front cover screws on hand dryer back base as the arrow marked.
2. Loosen 2 front cover screws on the hand dryer front&bottom.
3. Pull the front cover up then back a little to take it.
4. Pull the cover slowly and slightly because there are plastic locks on the top side.
5. **DO NOT** damage the top side plastic locks because it is used to fix the front cover on the base.

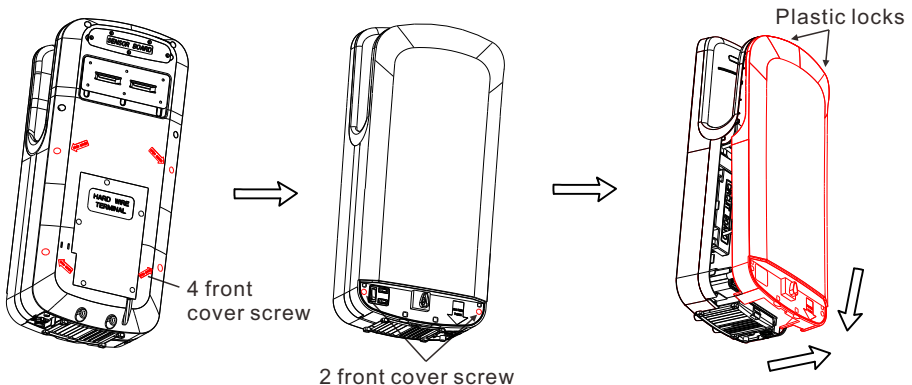

Replace Main Circuit Board, Sensor Receiver Board, Motor, Heat Element

Main Circuit Board: Move marked circuit board house cover and replace a new circuit board.

Sensor Receiver circuit board: .Move marked circuit board screw and replace a new one.

Replace Heat Element:

1. Move marked wind hole cover. Take the heat element out then replace a new one.

2. Replace wind hole cover. Be sure the air seal rubber at right location to avoid wind leakage.

Replace Motor:

1. Move marked wind hole cover and motor cover. Take the motor out and then replace a new motor.

2. Replace motor cover. Be sure the motor protection rubber&foam, air seal rubber at right location.

3. Replace wind hole cover. Be sure the air seal rubber at right location to avoid wind leakage.

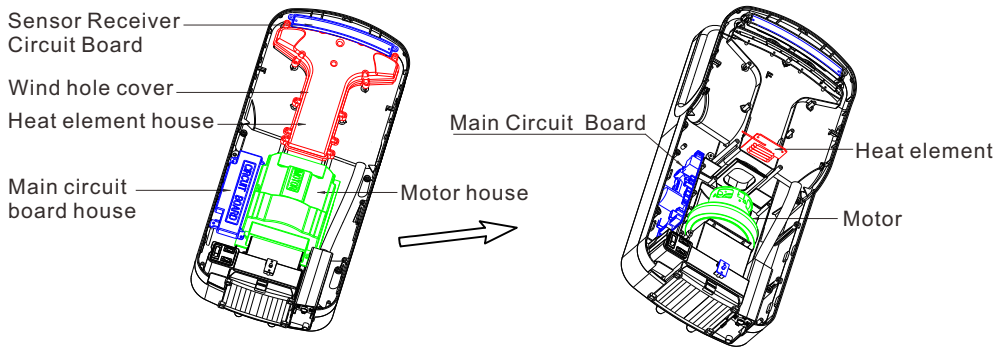

MAINTENANCE

Periodic cleaning of the unit is recommended. Remove cover and clean dryer dust lint.

Cleaning stainless steel

Stainless steel is highly resistant to rust, but there are some very strict cleaning and maintenance rules to be followed to prevent damage to its appearance.

General cleaning tips

Apply neutral detergents formulated for these purposes (non-ionic surfactants and citric acid).

Apply the detergent with soft cloth. Be careful with abrasive cloths. They may scratch the surface. Rinse with water until all the detergent has gone.

Residue from hygiene products, liquid soap, shampoos, bath gel, etc, can also damage surfaces.

Rinse the surface with plenty of water after use.

Limescale stains can be prevented by drying the surface with a soft cloth after use.

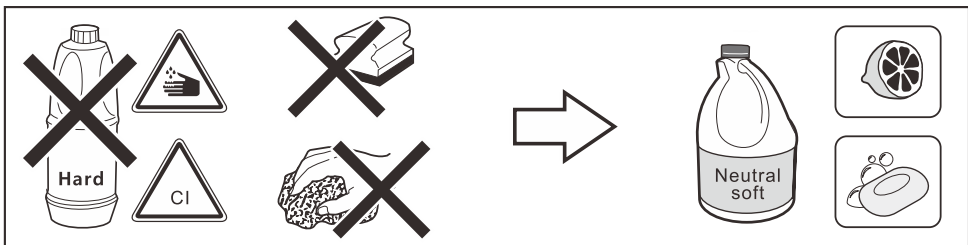

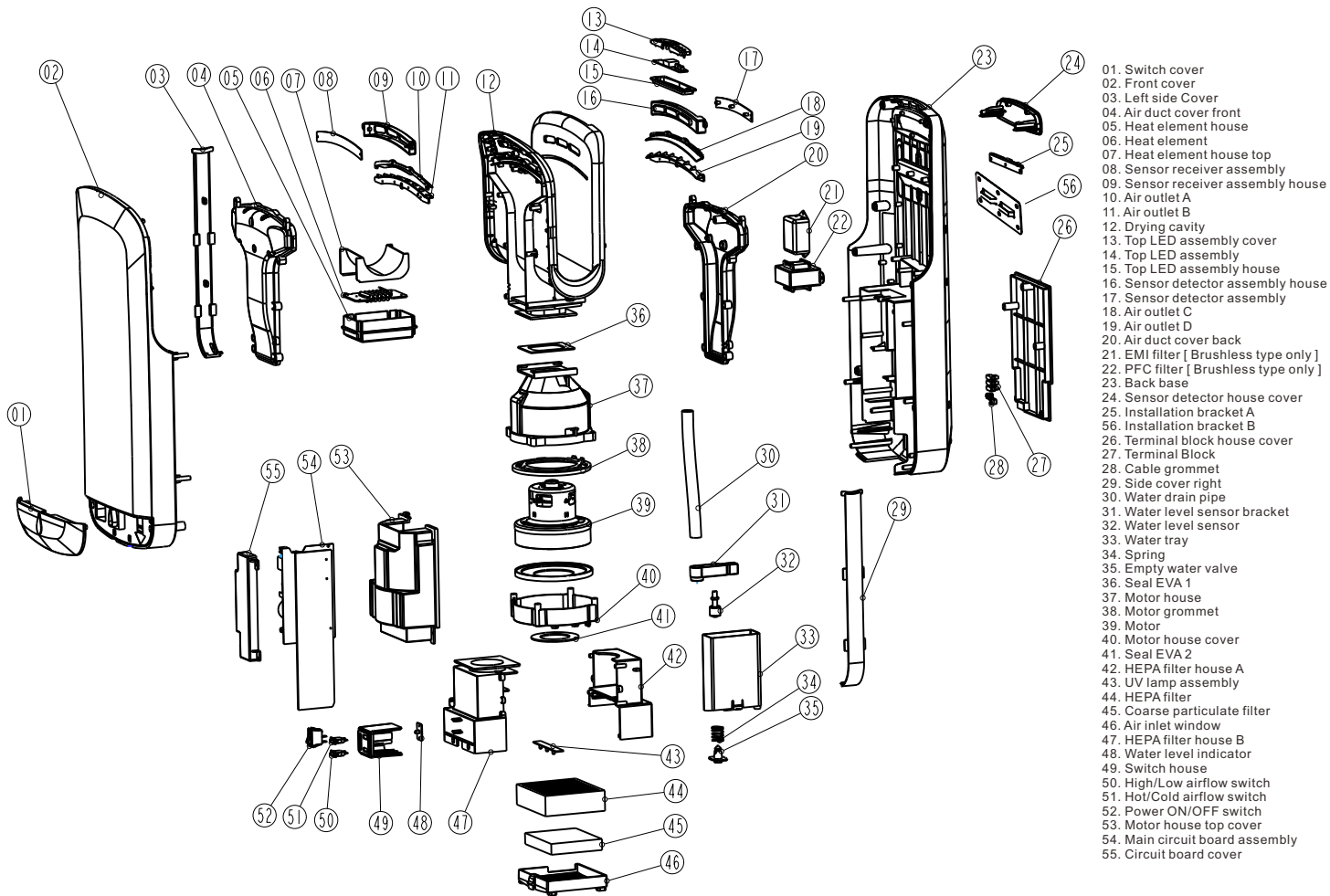

01. Switch cover
02. Front cover
03. Left side Cover
04. Air duct cover front
05. Heat element house
06. Heat element
07. Heat element house top
08. Sensor receiver assembly
09. Sensor receiver assembly house
10. Air outlet A
11. Air outlet B
12. Drying cavity
13. Top LED assembly cover
14. Top LED assembly
15. Top LED assembly house
16. Sensor detector assembly house
17. Sensor detector assembly
18. Air outlet C
19. Air outlet D
20. Air duct cover back
21. EMI filter [Brushless type only]
22. PFC filter [Brushless type only]
23. Back base
24. Sensor detector house cover
25. Installation bracket A
26. Terminal block house cover
27. Terminal Block
28. Cable grommet
29. Side cover right
30. Water drain pipe
31. Water level sensor bracket
32. Water level sensor
33. Water tray
34. Spring
35. Empty water valve
36. Seal EVA 1
37. Motor house
38. Motor grommet
39. Motor
40. Motor house cover
41. Seal EVA 2
42. HEPA filter house A
43. UV lamp assembly
44. HEPA filter
45. Coarse particulate filter
46. Air inlet window
47. HEPA filter house B
48. Water level indicator
49. Switch house
50. High/Low airflow switch
51. Hot/Cold airflow switch
52. Power ON/OFF switch
53. Motor house top cover
54. Main circuit board assembly
55. Circuit board cover